

MODEL 850

Two-Hand Control Module

- Continuous or Pulse Modes
- AC or DC Versions
- Socket-Mounted Design
- 5-Year Unconditional Warranty

DESCRIPTION

The **Model 850 Two Hand Control Module** is designed to be used with two palm or pushbutton switches, which must be closed within 0.5 seconds of each other to operate machinery. As long as both switches are pressed, the relay will remain energized in the continuous mode.

For applications requiring a pulse to initiate operations, the Model 850 can be set to produce a pulse output by connecting a resistor to pins 4 and 7. The resistor value in ohms should be 100,000 times the desired time in seconds ($R=100,000 \times T$).

The internal relay de-energizes on completion of the pulse, even if both switches are depressed. The relay de-energizes immediately, if either hand switch is released, in standard or pulsed mode.

The compact size of the Two-Hand Control Module allows installation into an existing control panel. It can be used with any type of machinery requiring safe, two-handed operation such as presses, punches, cutters, etc. The standard nominal supply voltages are 120VAC, 240VAC, 24VAC, 24VDC. Other voltage versions may be available by special request.



SPECIFICATIONS

MODEL	850-120VAC	850-240VAC	850-24VAC	850-24VDC
Supply Voltage	120VAC	240VAC	24VAC	24VDC
Max. Input Voltage	135VAC	265VAC	28VAC	28VDC
Min. Input Voltage	105VAC	215VAC	22VAC	22VDC
Power Consumption	2W			
Transient Protection	2500V FOR 10ms			
Pulse Time/Resistance	Minimum: 50ms/5K ohms		Maximum: 10 sec/1 megohm	
Input Switch Resistance	100 ohms max.			
Expected Relay Life	Mech: 10 million operations		Elec: 100,000 operations at rated load	
Contact Rating	SPDT 10A at 240VAC resistive			
Operating Temperature	- 20° to +131° F			
Humidity Tolerance	0 - 97% w/o condensation			
Case Material	ABS plastic			
Weight	5 oz.			
Mounting	11-pin socket (*not included)			

* order 11-pin socket number 51X016

OPERATIONS

STANDARD OPERATION (without resistor)

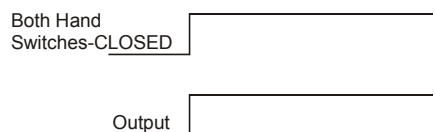

PULSED OUTPUT OPERATION (with resistor)

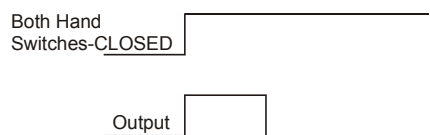

DIMENSIONS

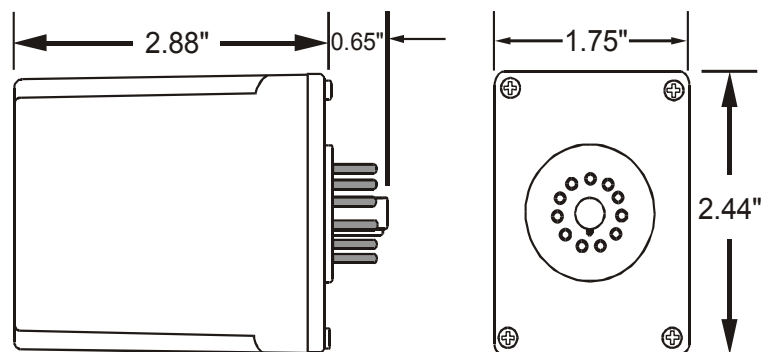

(dimensions have tolerance of ± 0.06)



TIME MARK
CORPORATION

11/2011

© 2011 TIME MARK CORPORATION

TIME MARK is a division of  AEMT, Inc.

MODEL 850 Two-Hand Control Module

READ ALL INSTRUCTIONS BEFORE INSTALLING, OPERATING OR SERVICING THIS DEVICE.
KEEP THIS DATA SHEET FOR FUTURE REFERENCE

GENERAL SAFETY

POTENTIALLY HAZARDOUS VOLTAGES ARE PRESENT AT THE TERMINALS OF THE MODEL 850.
ALL ELECTRICAL POWER SHOULD BE REMOVED WHEN CONNECTING OR DISCONNECTING WIRING.
THIS DEVICE SHOULD BE INSTALLED AND SERVICED BY QUALIFIED PERSONNEL.

Installation Instructions

INSTALLATION

Mount the module's socket in a suitable enclosure.

Connect AC operating power, two switches and the load to the appropriate socket terminals referring to the pin diagram.

For pulsed operation— Install a resistor across terminals 4 and 7. The resistor should be 100k Ω for each 1 second of delay required (example: 50k Ω for a 0.5 second delay).

Install the module in the socket and apply power.

NOTE: When installing the Model 850 Module in areas of high humidity or contamination, it is recommended that the base area and all exposed metal parts of the socket be coated liberally with a good quality silicone grease, such as Dow Corning DC-4 or DC-4X. Insert the unit into the socket and wipe off excess grease around the base. This will prevent the entrance of moisture and other contaminants into the base and socket areas.

OPERATIONS

STANDARD OPERATION (without resistor)

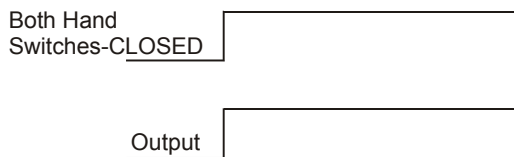

PULSED OUTPUT OPERATION (with resistor)

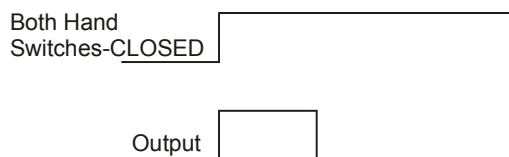

PIN CONNECTIONS

The Model 850 Two Hand Control Module requires a standard 11-pin socket for mounting and uses a standard pin configuration. Refer to the pin diagram below, or on the control module for pin connections.

PIN DIAGRAM

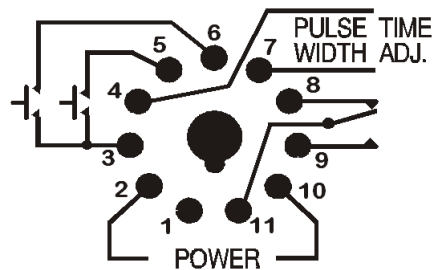

Shows No Power Applied

TROUBLESHOOTING

Should the Model 850 fail to operate properly, check that the operating voltage is present and of the correct level. Check all fuses and verify that all wiring connections are correct. Should problems persist, contact the manufacturer for assistance.

WARRANTY

This product is warranted to be free from defects in materials and workmanship, and is covered by our exclusive **5-year Unconditional Warranty**. Should this device fail to operate for any reason, we will repair it for five years from the date of manufacture. For complete warranty details, see the *Terms and Conditions of Sales* page in the front section of the Time Mark catalog or contact Time Mark at 1-800-862-2875.



TIME MARK
CORPORATION

11/2011

© 2011 TIME MARK CORPORATION

TIME MARK is a division of  AEMT, Inc.